

PICOSECOND TIMING SYSTEM

Dominique Monnier-Bourdin,^{*} Bernard Riondet,^{**} Greenfield Technology, Massy 91300, France
 Stéphane Perez,[#] CEA/DIF, F-91297 Arpajon, France

Abstract

The instrumentation used to synchronize large physics experiments often require timing with resolution down to a few picoseconds. These experiments also require different sampling rates for multi-shot or single-shot triggering for each instrument distributed in a large area.

Greenfield Technology offers a commercial solution with a Picoseconds Timing System built around a central Master Oscillator which delivers a serial data stream over an optical network to synchronize local multi-channel digital delay generators. This system is able to provide several hundred triggers pulses with coordinated 1ps timing resolution and jitter below 15 ps. The timing signals may be distributed over an area up to 100,000 square feet.

The properties of this Picosecond Timing System are presented herein with actual measurements taken and functions performed from recently deployed systems. The existing systems referenced are as follows: Laser MegaJoule Prototype, France; Ligne d'Intégration Laser, France; Petawatt Laser Applications and Synchrotron Soleil, France.

Packaging of the local Digital Delay Generators at each trigger point has been installed in several form factors based on the application. Benchtop, 19" RackMount, cPCI and PXI cards have all been used. Additionally, trigger pulse shaping options make the Greenfield Picosecond Timing System an ideal solution to synchronize Synchrotron experiments, High Energy Lasers or other large physics experiments.

INTRODUCTION

The purpose of a timing system is to synchronize all the equipment used in picoseconds lasers experiments. A typical picosecond laser system application is shown below in Figure 1.

The 80 MHz oscillator (or front end) provides a fast pulse laser at low power. This pulses are amplified by a "laser chain" composed of an amplifier running at 100 Hz and then by a second amplifier running at 10 Hz.

At the output of the "laser chain" the beam laser has sufficient optical power to generate specific anticipated effects such as mechanical compression, plasma heating and ignition in a "target chamber" where the experiment is done.

To control the proper operation of the laser system several kinds of diagnostics (measurement and control)

^{*} d.monnierbourdin@greenfieldtechnology.com
^{**} b.riondet@greenfieldtechnology.com
[#] stephane.perez@cea.fr

are implemented. These include a photodiode, digitizer, calorimeter, CCD camera and streak camera.

In general the oscillator, the laser chain and the target chamber are situated in three separate areas, often separated by considerable distances.

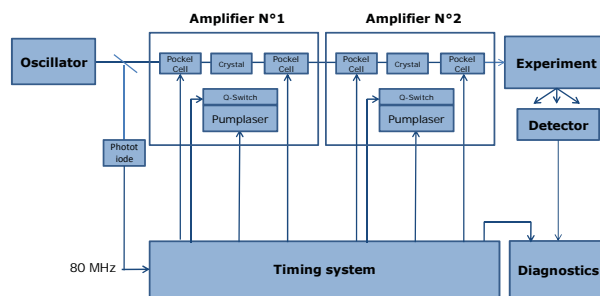

Figure 1: Typical picoseconds laser system.

TIMING REQUIREMENT

The timing requirement for a typical picoseconds laser system is shown in Table 1. In some applications there are others functions like a flash (typically 1ms before the shot) or a beam shutter or compressor.

Table 1: Timing Requirement

Equipment	Function	Frequency	Delay before the Shot
Amplifier N°1	Pump laser	100 Hz	2 ms
	Q-switch	100 Hz	10 ns
	Pockels cell on /off	100 Hz	1 μs / -1 μs
Amplifier N°2	Pump laser	10 Hz	300 μs
	Q-switch	10 Hz	10 ns
	Pockels cell On /Off	Single shot	0.5 μs / - 1 μs
Diagnostics	Digitizer, Streak camera	Single shot	10 ns / 1 ns
Timing system	Synchronise the equipment	5 repetitive frequency 2 single shot	- 1 second to up 1 second

TIMING SYSTEM

To meet the requirements, Greenfield Technology proposes a picoseconds system that provides several hundred trigger pulses to equipment distributed over a large area of up to 100,000 square feet. The system architecture is shown in Figure 2.

- A central Master Oscillator transmitter provides Master triggers and time base (synchronised on external clock) and allows the transmission of them via a serial data stream to synchronize local delay generator.

- An optical network allows the distribution of the data stream over the different areas.
- A local delay generator receives the optical data stream, decodes (time base and master triggers) and then generates local delayed pulses to trigger the different devices.

This architecture is designed to accept 256 local areas and generate 2500 delayed triggers.

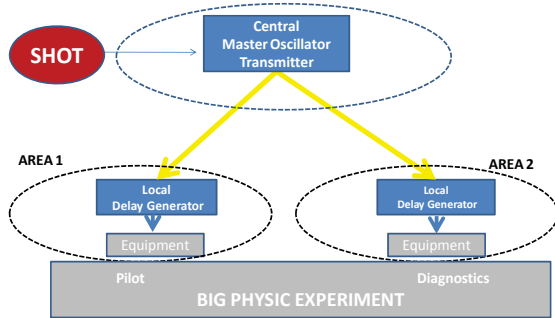

Figure 2: Timing system architecture.

CENTRAL MASTER TRANSMITTER

The Central Master Transmitter (Reference Model GFT3001) is the heart of the timing system. The clock reference of the GFT3001 can be external or internal. In some applications the GFT3001 can also generate a clock for time reference for certain kinds of Laser Oscillators also. The GFT3001 is able to respond to an external hardware Single Shot trigger or generate an internal Single Shot trigger. See Fig. 3.

To prevent erroneous outputs, the user can stop the Single Shot with a Hardware level preset. An additional security measure is enabled if the external clock reference is lost, returning the Central Master Transmitter to a preset frequency.

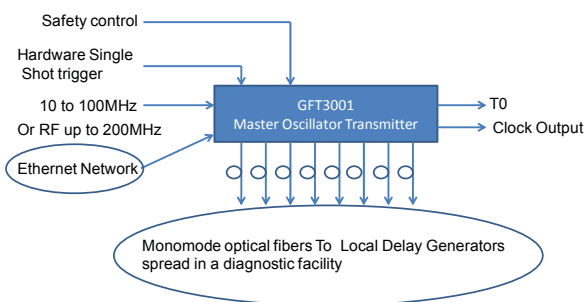

Figure 3: Central Master Transmitter interface.

LOCAL DELAY GENERATORS

All local digital delay generators include 8 independent channels that drive electrical pulses under 50Ω impedance. The specific model is selected for each application with consideration over form factor, jitter, rise times and other variables (See Table 2).

Table 2: Specifications of Delay Generators

Local delay generator	Resolution Ch number	Jitter rms Ch./ Ch.	Pulse Amplitude	Pulse Width	Pulse Rise time
GFT1208, cPCI	1ps 8 ch	15 ps	10V or 3V	0.2 to 10µs	1ns
GFT9404, PXI	1ps 4 ch	15 ps	2 To 5 V	0.2 to 10µs	0.7ns
GFT1004, 19"1U	1ps 4-10 ch	10 ps	2.5 to 10 V (*)	100ns to 10ms	0.7 ns
GFT1004, 19"1U Option TTL	1ps 4-10 Ch	10 ps	2.5 to 6 V (**)	100ns to 10ms	3 ns
GFT1504, Box ½ 19"	1ps 4-10 Ch	10 ps	2.5 to 10 V (*)	100ns to 10ms	0.7 ns

(*) Channel option: Amplitude 32 V / 1 µs or 5 to 20 V on each output
(**) pulse polarity positive or negative

CONTROL

All parameters in the Timing System may be controlled with a front panel interface or over a remote network. An embedded control application allows any browser to control the devices. Other software options to manage the timing system include Labview, Tango or Epics [1].

Sequence

The user can program the sequence of the laser shot, as shown in Figure 4:

- Repetitive single shot
- Single burst
- Repetitive single burst
- Single shot

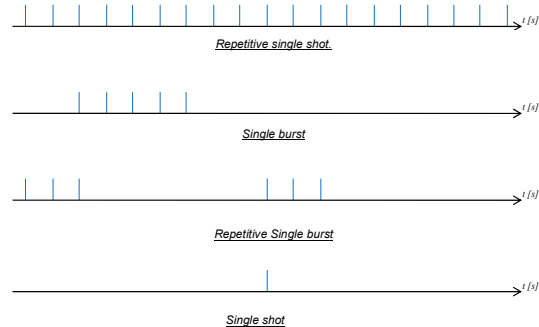

Figure 4: User-programmable laser shot sequences.

During setup or maintenance, the user has an option to define additional independent pulse sequences. A test protocol or setup protocol may differ from operational use. One example would be to toggle between two sequences as shown in Figure 5.

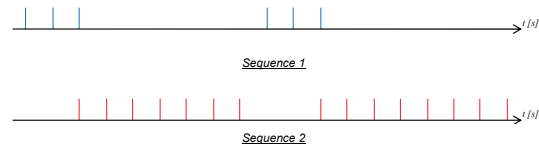

Figure 5: Example of pulse sequence toggling.

Channel Parameters

For each delay channel you can select the source of trigger. There are seven sources for triggers possible: five Repetitive and two Single Shot.

Delay Chain

Channel delays can be chained together. This would result in the delay of a channel being a function of the delay of another Channel.

Output Pulse

Each output pulse can be independently adjustable in amplitude, width and polarity. All the output pulses can be separately inhibited by the user but also by an outside signal supplied by a safety control.

PERFORMANCE

The timing system is able to generate very accurate trigger pulses for a range of equipments at pre-programmed times with desired delays. Trigger pulses during the last 2 seconds of the shot cycle require jitter 15ps or less and a resolution of less than 30 ps.

Figure 6 shows the local delay generators (Model GFT1004) used on the line laser of the large area installation at LULI, France.



Figure 6: View of LULI timing system. In this installation the users have measured the long-term jitter in a temperature stabilized environment. The results are shown in Figure 7.

Jitter was 30ps peak to peak. To measure the jitter, a streak camera was used. The jitter of the streak camera is +/- 15 ps peak to peak [2].

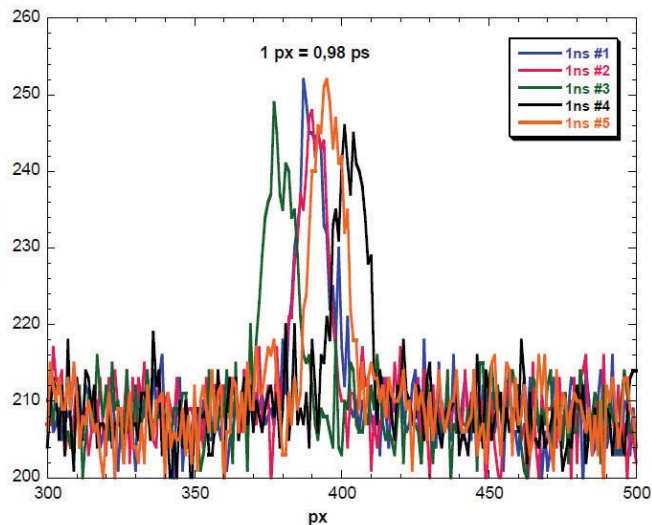

Figure 7: Result of timing system jitter.

CONCLUSIONS

The timing system proposed by Greenfield Technology, with different packaging options at each trigger point, excellent jitter and stability performance, and a range of pulse trigger shapes, makes this system the ideal solution to synchronize picosecond laser systems and other application such as Petawatt, High Energy Lasers, Synchrotrons and High Energy Physics experiments.

For synchrotron applications the timing system can be configured to provide 256 master triggers (single shot or repetitive) with flexible control of pulse and delay sequences.

REFERENCES

- [1] M. Pina et al., "Cliex-Apollon synchronization and security system," MOPPC405, ICALEPCS 2013, to be published; www.JACoW.org
- [2] Mesures de jitter sur LULI – Octobre 2012, LULI internal document.