

Features

- 20 independent delay channels
100 ps delay resolution
50 ps channel to channel RMS jitter
- Output pulse 1.5 to 5 V into 50 Ω , with 1 ns rise time and independent control of pulse width, polarity, amplitude, burst and MUX mode
- Up to 50 MHz trigger rate
- 6 triggers sources: two External with pre-scaler or three internal timers or one command
- External clocking up to 240 MHz
- Controlled via Ethernet or USB
- Output pulse options: 10 V or 50 V or LVDS level

Applications

- System Laser Timing Control
- ATE Application
- Laser Pulse Piking
- Precision Pulse Application
- Instrument Triggering
- Components Test Equipment
- Multi-clock generation
- Serial data generation (adjustable in skew) with "burst" and "MUX" mode

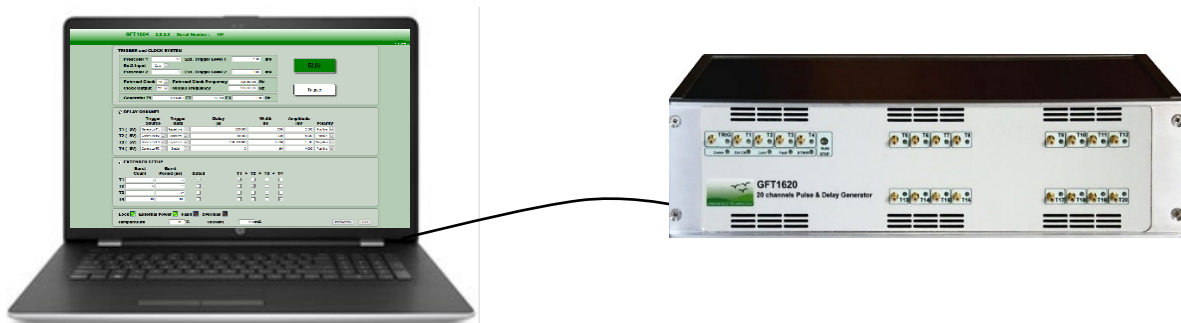

GFT1620 generator and Laptop 11" with IHM to control settings.

Description

The model GFT1620 compact Pulse & Delay Generator provides 20 independent delayed pulses. Delays up to 100 seconds can be programmed with 100 ps resolution and channel to channel jitter less than 50 ps RMS.

SMB outputs deliver 1.5 V to 5 V into 50 Ω with 1 ns rise time pulses. Pulse amplitude, polarity, width and burst count are adjustable on each output channel. In option, pulse amplitude can be 3 V to 10 V or 15 V to 50 V into 50 Ω or LVDS level.

The model GFT1620 offers triggering by two inputs or three internal synchronized Timers (adjustable from 0.001 Hz to 50 MHz) or software command for each selected delay channel. Any trigger rate may be set as one-shot or repetitive.

The Gate Input allows to quickly inhibit all selected channel Outputs. This input function can be selected as an additional External Trigger.

The generator has an internal 100 MHz TCXO clock reference and accepts an external clock reference from 10 MHz to 240 MHz sine or square wave.

On front panel LED indicators are included to indicate when each input or output are running, and a RUN/STOP button allows to enable/disable all output channels.

The GFT1620 parameters can be remotely controlled via Ethernet (LAN) or via USB to UART. Web page, from embedded Web server, provides easy method to configure settings from your laptop without any software application.

Application example: This pulse generator is well suited to synchronize all the devices of a Picosecond Laser System with a single compact unit and one GUI. In this application the "Clock input" of the pulse generator receives a reference signal (80 MHz for example) from a laser oscillator via an O/E (optical to electrical converter like a GFT300). From the pulse Generator each amplifier (Pump-laser, Q-switch, Pockel cell driver ...) or diagnostic instruments (Digitizer, Calorimeter, CCD camera ...) can receive repetitive or single pulses (adjusted in rate, delay, amplitude, polarity, and pulse width) synchronized on "Clock input" with a very low jitter. From Pulse/Delay Generator 4 GPIO (input or output) under software control allow command to the low-frequency devices of the Laser System for security or control.



GFT1620

20 channel Pulse & Delay Generator

Specifications

Delay channels	
Number	20 independents
Range	100 seconds
Resolution	100 ps
RMS jitter	<50 ps + delay x 10 ⁻⁷ , channel to channel <1 ns, external trigger to any channel <50 ps, external clock to any channel
Accuracy	<250 ps + delay x 10 ⁻⁶
Time base	Internal 200 MHz, ±1 ppm stability
External Trigger Mode	
Input "TRIG"	Rate single or repetitive up to 40 MHz, with prescaler, adjustable threshold from +100 mV to +5 V (step 1 mV), adjustable positive or negative slope and 5 ns min pulse width
Trigger delay	<85 ns (insertion delay)
Internal Trigger Mode	
Rate repetitive	From three Timers with frequency = 0.01 Hz to 50 MHz (in step of 5 ns)
Rate single	Synchronized on Trigger input or internal Timers or soft command
Channel Output pulse T1 to T20	
Amplitude	1.5 V to 5 V in step of 1 mV into 50 Ω or 3.0 V to 10 V in step of 2 mV into high impedance (> 1 KΩ)
Rise/Fall Time	1/1 ns into 50 Ω or 2/2 ns into high impedance @ full scale
Width	10 ns to 10 s in step of 5 ns
Pulse Polarity	Positive or Negative
Burst Mode	Burst count = 1 to 1 000 000 000, adjustable period in step of 5 ns
MUX Mode	Any channel may be ORed' to all outputs (in a same group of 4)
Narrow pulse mode	It allows min width of 500 ps in step of 100 ps on two channel outputs with option 5
Connector	SMB
External Clock reference	
Threshold	0 V, internal 50 Ω
Level	Min -10 dBm, typical 6 dBm
Frequency	10 MHz to 240 MHz, user programmable in steps of 0.25 MHz up to 120 MHz then user programmable in steps of 0.50 MHz
Clock output	
Level	>500 mV p-p, into 50 Ω, AC coupling
Frequency	100 MHz if internal clocked or same as external clock if external clocked
Gate or second trigger or daisy chaining	
Function	Gate or second External Trigger with adjustable threshold or daisy chaining to second GFT1620
Input	Active high or low in gate mode, positive/negative slope with rate <40 MHz in trigger mode
GPIO: Input or output lines	
4 x GPIO	Input or output, 0 or 3V level, impedance >20 kΩ input & 100 Ω output
General	
Interface Control	USB to UART, Ethernet 10/100 Mb/s
Software tools	Free Drivers for Windows 10/11 and Linux, USB application with GUI is furnished
Power consumption	7.5 W to 25 W according to configuration
Power supply	External AC (90 - 240 V / 50 - 60 Hz) to DC (5 V, 8 A) adapter furnished
Size and Weight	330 mm x 2U x 140 mm, 2.1 Kg
Options	
Option 1:	Only 12 channels: For lower cost, channel number can be reduced
Option 2:	Only 16 channels: For lower cost, channel number can be reduced
Option 3:	(Bank of 2 channels) 3 V to 10V channel output, width = 10 ns to 10 ms, rise/fall time = 1/1 ns typ. into 50 Ω
Option 4:	(Bank of 2 channels) 15 V to 50 V channel output, width = 50 ns to 5 μs, rise/fall time = 3/15 ns into 50 Ω, 10 ps channel to channel jitter for short delay
Option 5:	(Bank of 1 channel) with a max of 2 differential LVDS or HSTL outputs, 175 mV to 1200 mV, adjustable width 10 ns to 1 s, rise/fall time = 0.5/0.5 ns into 100 Ω differential <u>Narrow pulse mode</u> : it allows min width of 500 ps in step of 100 ps
Option 6	5" SMB to BNC cable
Option 7	Rackmount kit
Option 8	Jitter improvement (<100 ps rms) between external trigger and outputs, min width reduced to 1 ns

Operating Information

Block diagram of the generator

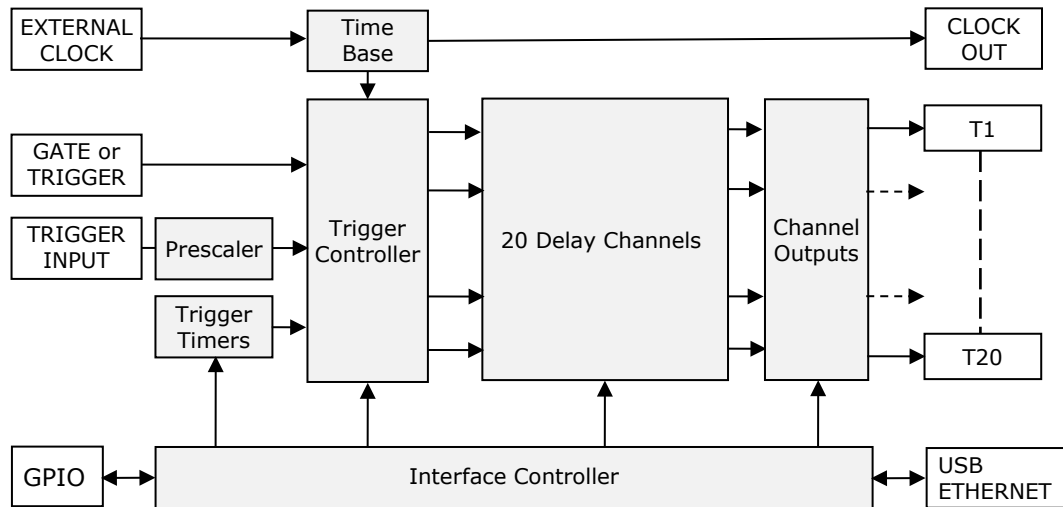

Block Diagram of the generator

Time base: This function provides a 200 MHz time base from an internal reference or an external 10 MHz to 240 MHz reference. The internal time base is available (Clock out) on the rear panel.

Trigger controller: This function provides 2 Trigger Modes.

-**External Trigger Mode:** In this mode, a rising (or falling) edge on input "Trigger input" triggers all delay channel. On every channel trigger rate can be single or repetitive or inhibited.

A Pre-scaler may be used to divide the Trigger Input frequency by integer value from 1 to 1 000 000 000.

-**Internal Trigger Mode:** In this mode delay channels can be triggered from 3 frequency programmable Timers. On every channel trigger rate can be single or repetitive or burst or inhibited.

The seven (7) Trigger sources that are possible for each channel are presented in a below chart.

	Trigger sources						
	Trigger input	Gate input	Timer N°1	Timer N°2	Timer N°3	Command	Inhibited
External mode	X	X					
Internal mode			X	X	X	X	X

Trigger sources

"**Gate Input**" allows to quickly inhibit all selected channel Outputs. This input function can be selected as a second External Trigger or an input/output for daisy chaining two GFT1620 generators.

Run or Stop button enables or disables the output for any channels.

Delay Channel: They are 20 independent delay channels. The delay from selected trigger source is programmable up to 100 seconds in 100 ps increments.

Channel Output

Each delayed output pulse (T1 to T20) can be independently adjustable in level (1.5 V to 5 V in 1 mV steps), width (10 ns to 10 s in 5 ns steps), and polarity, and may be ORed' to all other outputs. The outputs are designed to drive 50 Ω load. On "High impedance" load, output level will be twice.

In option every channel output level can be 3 V to 10 V or 15 V to 50 V into 50 Ω or under LVDS standard (ask to the factory for mixed channel output level configuration).

Burst mode: On each Channel Output the number of pulses can be adjustable with Burst count and Burst period.

Narrow pulse mode: (available with option 5) This mode uses two delay channels, one to start the output pulse, and the other one to stop the pulse. So, in this mode, the output pulse can be narrower and precisely adjusted in time.

Interface Controller:

It manages internal functions and user interface. All the parameters can be remote controlled via USB to UART and Ethernet (10/100 Mb/s).

All parameters' values are automatically saved and can be stored in 8 different user sets.

"**GPIO**": Four lines, input or output, under software command allow to control other devices.

Example of channel outputs mode

Mode repetitive and single

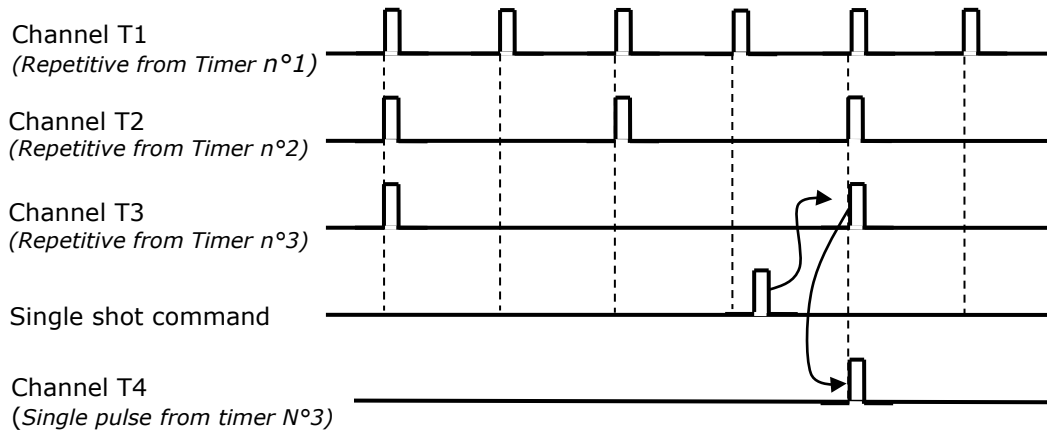

Mode burst and Mux

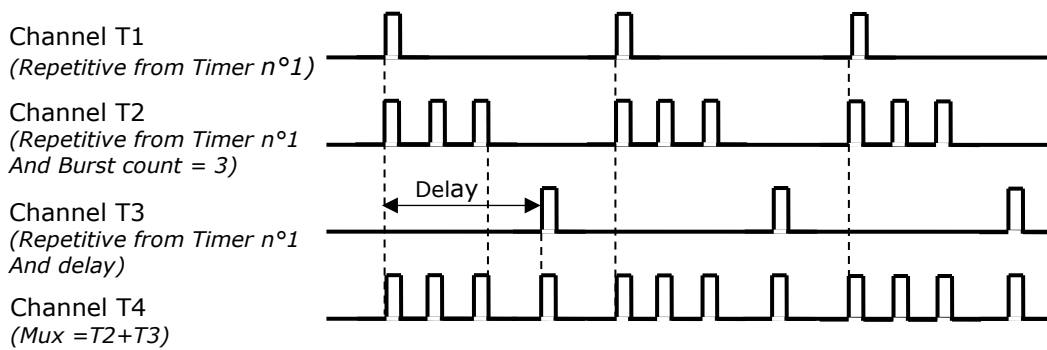

Pulse picking

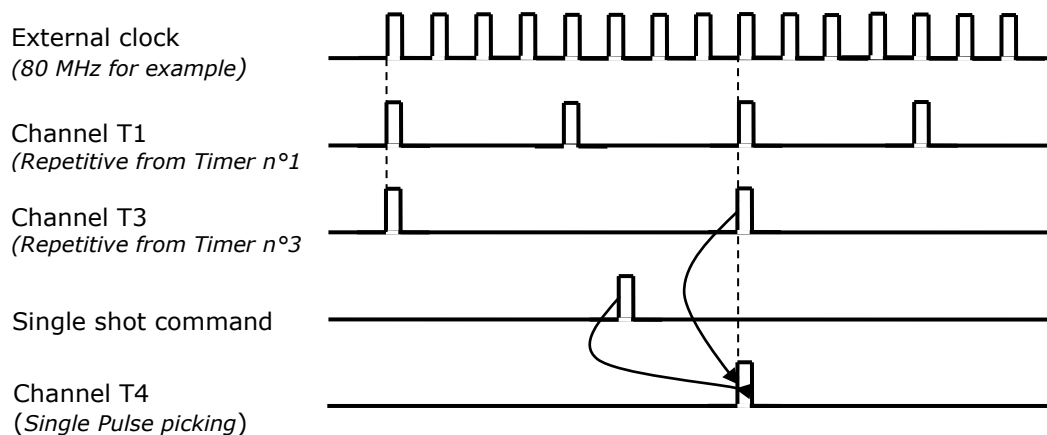

Example of typical output pulse

5 V output pulse into 50 Ω load
 $R_t = 680$ ps, $F_t = 740$ ps

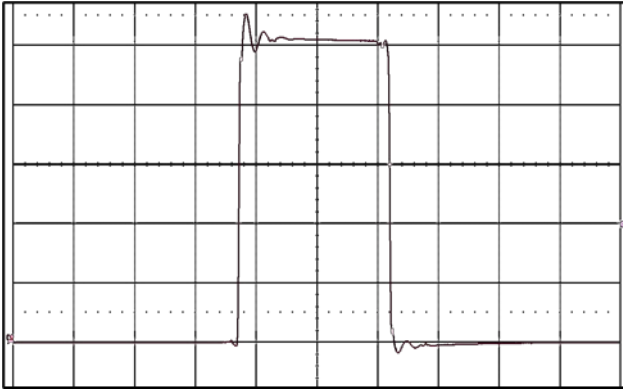

(20 ns/div, 1 V/div)

10 V output pulse into high impedance load
 $R_t = 1.70$ ns, $F_t = 1.90$ ns

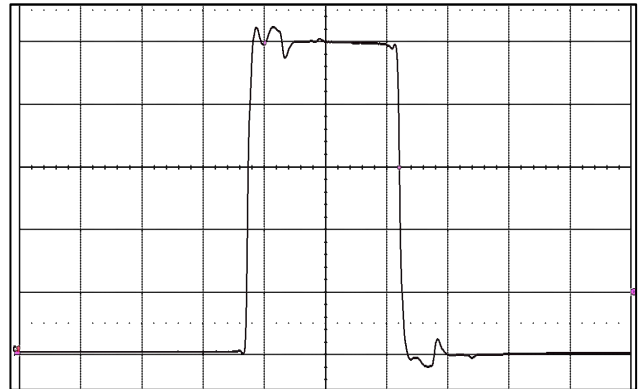

(20 ns/div, 2.0 V/div)

10 V, 10 ns pulse width with option 3
 $R_t = 790$ ps, $F_t = 770$ ps

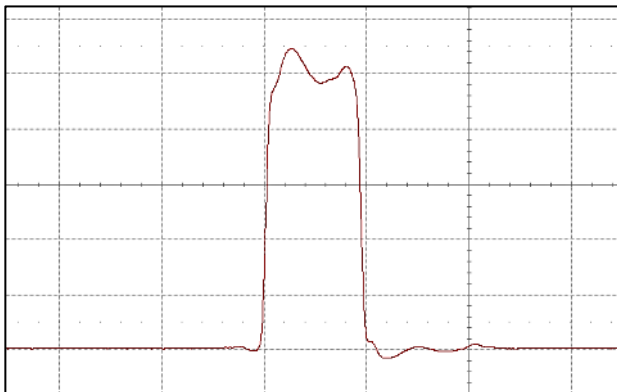

(10 ns/div, 2.0 V/div)

10 V, 10 ms pulse width with option 3
 $R_t = 800$ ps, $F_t = 800$ ps

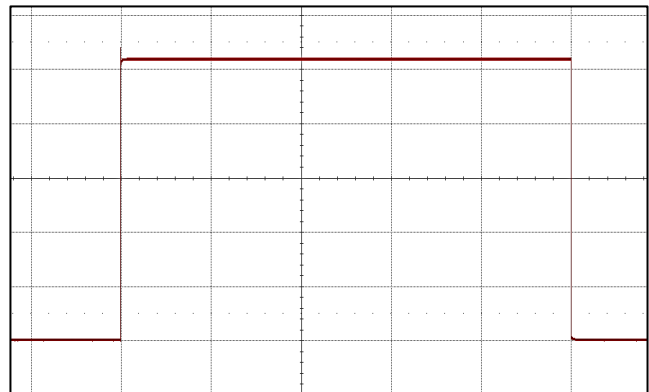

(2 ms/div, 2.0 V/div)

10 ns pulse width in burst mode with option 3
 10 V into 50 Ω at 50 MHz rate

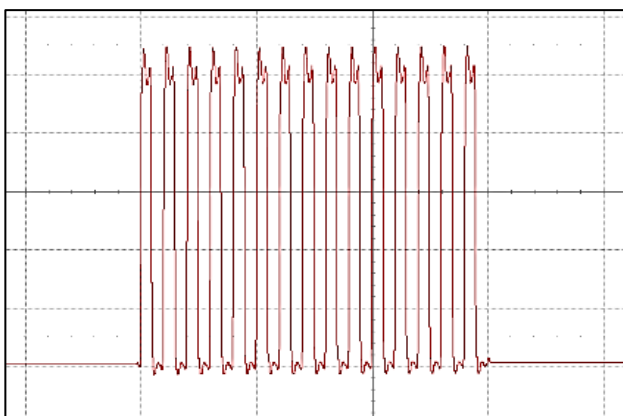

(100 ns/div, 2.0 V/div)

500 ps width in narrow pulse mode with option 5
 1.1 V and 500 to 1500 ps width (step of 100 ps)

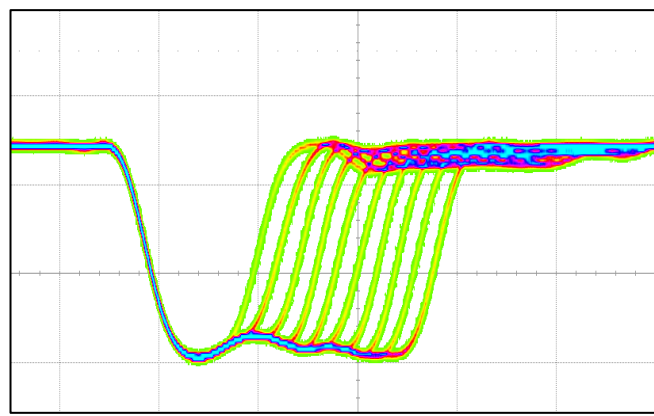

(500 ps/div, 0.5 V/div)

View from scope in infinite persistence

Control and software tools

There are two ways to control the generator.

Easy remote way via Ethernet and control panel web pages. Web page, from embedded Web server, provides easy method to configure settings from your laptop without any software application.

- A Main menu allows to display and control:
 - Trigger and clock system (trigger level, pre-scaler, clock input/output, trigger generators F1 or F2 or F3).
 - Delay channel (Trigger source, trigger rate, delay, amplitude / width/polarity of output pulse)
 - Extended delay channel settings (burst mode, gate, and MUX mode)
 - "RUN" button enables the output for all delay channels.
 - "Trigger" may be used to enable a "single trigger" synchronized with the selected trigger source
- A secondary menu selected with "parameter" button allows to change the IP address and configure specific parameters.
- Another secondary menu selected with "GPIO" button allows to configure Input/output lines.

The configuration information (all the settings) of the instrument is stored and saved in the GFT1620.

The web page can be opened via Edge, Mozilla Firefox or Chrome. After connecting a cable from the generator Ethernet port to your computer network, enter the generator IP address into your PC's browser (the IP address can be identified in User's manual). The browser will automatically open the control panel web page on your PC.

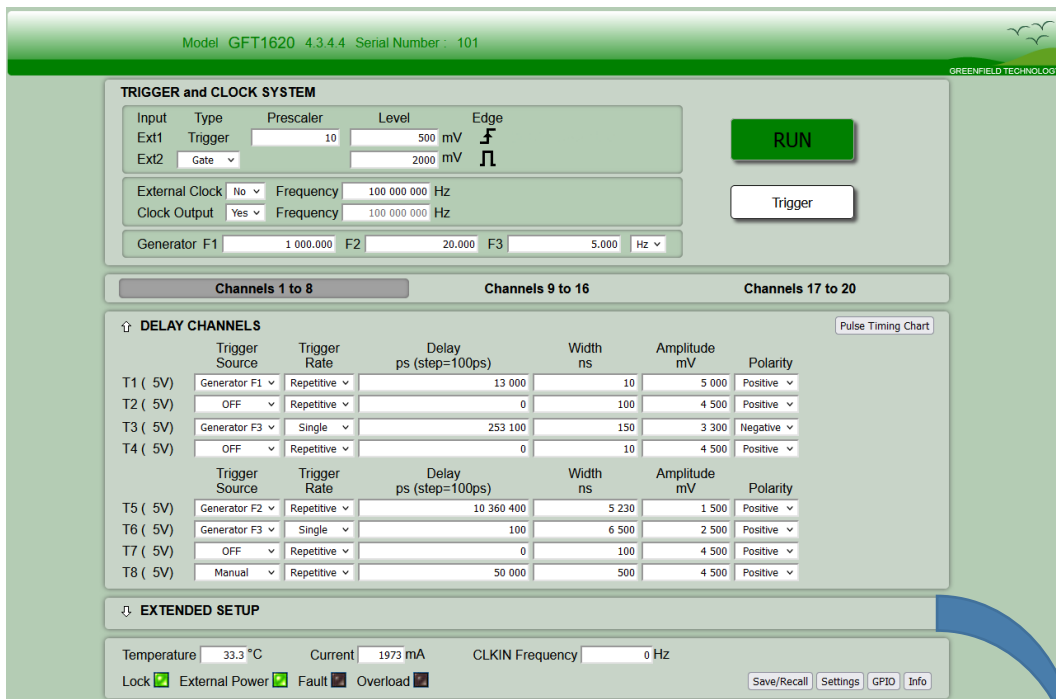

Control panel web page

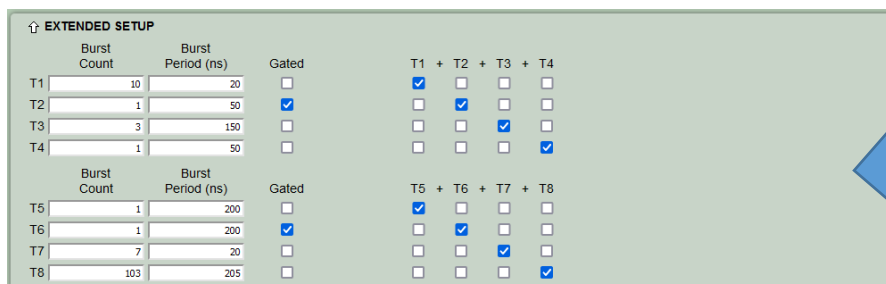

Extended Setup panel

General remote way via Ethernet or USB and software application (see examples in the User's manual)

Stand-alone: The GFT1620 generator can be used without PC; PC is only needed to change the pulse characteristics. If this mode (auto POWER and auto RUN are ON) when the unit is powered up, it will start output pulses automatically.

Front and rear panel

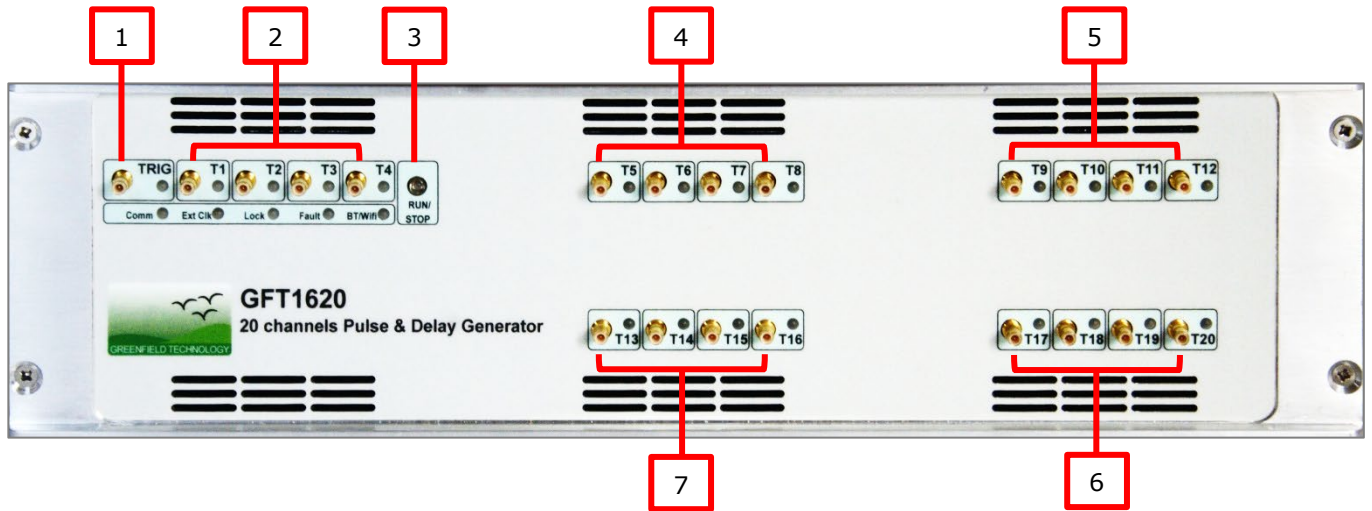

Front panel



Rear panel

Connectors, switch

Front panel		Rear panel	
• Connector		• Connector	
1	Trigger input: BNC connector	8	Gate input: SMB connector
2	T1 to T4 channel outputs: SMB connectors	9	Clock input & output: SMB connectors
4	T5 to T8 channel outputs: SMB connectors	A	USB connection: USB 2.0 B connector
5	T9 to T12 channel outputs: SMB connectors	B	LAN connection: RJ45 connector
6	T13 to T16 channel outputs: SMB connectors	C	GPI0: SHM-103 Samtec connector
7	T17 to T20 channel outputs: SMB connectors	D	+5 V DC power plug: Jack 2.10 mm
• Switch			
3	Power On/Off or Run/stop channel outputs		

Pulse shaping modules

Model	Description
GFT101	Electrical-to-optical Pulse Converter
GFT200	Optical to electrical pulse converter provide 10 V under 50 Ω
GFT300	Sub nanosecond Pulse Stretcher from pick up diode to provide GFT1620 clock reference
GFT614	1 to 4 lines, 150 MHz 50 Ω line Driver Module
GFT632	32 - 70 V, <2 ns rise time under into 50 Ω, Pulse Generator
GFT644	4 channel, 150 MHz, 50 Ω line Driver Module